

Main Features

The basic structure consists of an all steel base, mast and turntable. The base has front and rear slots to allow a forklift truck to move the machine safely and easily within the workspace.

The mast is of special profile design, inside which, the electrical cabinet, film carriage and drive motor are situated.

As standard there is a quality powder coat finish, with no external wiring or limit switches. Clear identification labels aid simple operation.



Technical Data

- Hinged Mast
- 1650mm diameter turntable
- Soft start/stop by frequency inverter with return to start position
- Powered film carriage with variable speed and safety cut out on base to prevent trapping
- Adjustable mechanical film brake
- 4 wrapping programs: single 1, single 2, cross wrap, rainproof
- Independently adjustable top and bottom reinforcing wraps
- Independently adjustable reinforcing wraps at any point in the cycle
- Automatic load height detection by photocell, with adjustable top overlap
- PLC controlled, with bespoke display control panel
- Ergonomically designed control panel

Model	BEX 200
Max. Pallet Size	1200 x 1100 x 2400 (h) mm
Max. Pallet Weight	2000 kg
Power Requirements	230 Volt Single Phase
Power Consumption	0.8kW

The Sontex logo consists of the word "Sontex" in a white, serif font, set against a solid blue rectangular background.

Sontex (Machinery) Limited
Unit B1, Cartwright Street
Cleckheaton, West Yorkshire BD19 5LY
Telephone: 01274 872299 Fax: 01274 862829
Email: info@sontex.co.uk www.sontex.co.uk

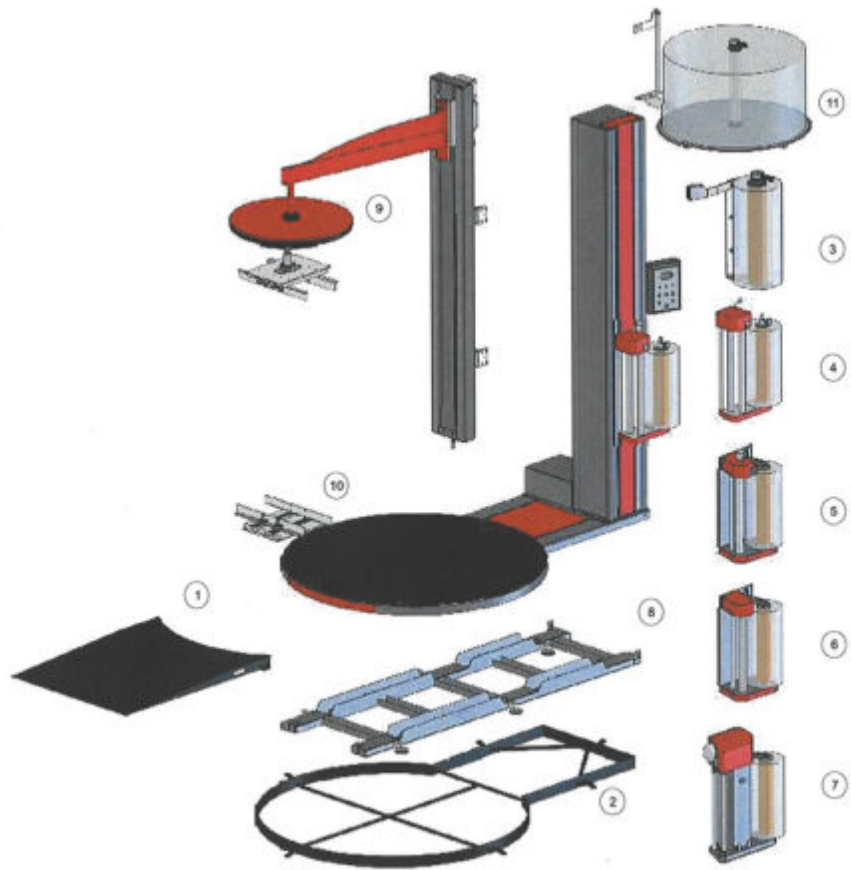

- 1 Access ramp
- 2 Floor embedding frame
- 3 Direct film brake
- 4 Mechanical film brake (standard)
- 5 Mechanical film brake plus
- 6 Electromagnetic film brake
- 7 Powered film pre-stretch
- 8 Weighing cells with display
- 9 Powered top platen
- 10 Flat load holder
- 11 Twin reel holder

